

MJ

MJ500/600/700

Can be connected to commercially available analog output scales

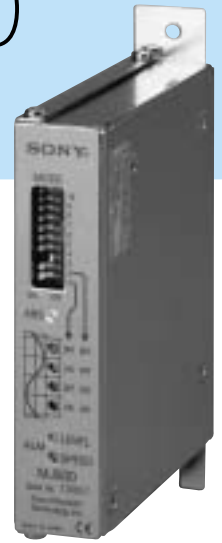

- Capable of 80 to 4000 divisions.
- Number of divisions
 - MJ500: 80 to 400 divisions
 - MJ600: 500 to 1024 divisions
 - MJ700: 1200 to 4000 divisions
- The MJ500/600/700 also allow DC offset compensation, gain compensation and phase difference compensation.

Example for connection

Scale	Head	Cable	Interpolator
SL700	PL101	CE08 CK-T12/13/14/15/16	MJ500/600/700

Dimensions

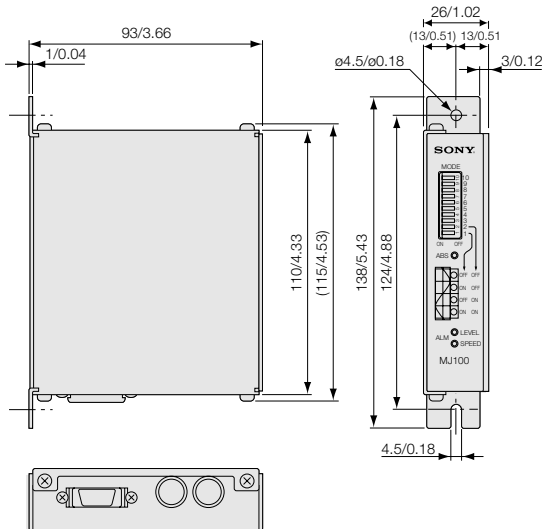

System Configuration

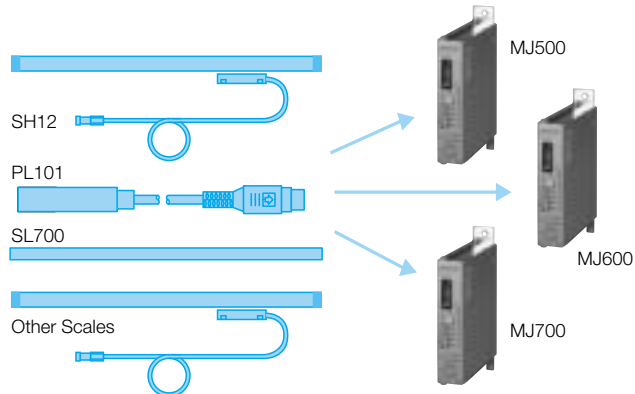

Unit : mm/inch

Specifications

Model	MJ500	MJ600	MJ700
Power supply	5 V (4.5 V to 8 V)		
Power consumption	4 W		
Output interface	Line driver (EIA-422 compliance)		
Outputs	A/B quadrature, Z phase, alarms		
Number of divisions	400,360,300,240,120,100,80; 1/2 of each of these (which does not satisfy the synchronized reference point specifications.)	1024,1000,960,800,720,640,512,500; 1/2 of each of these (which does not satisfy the synchronized reference point specifications.)	4000,3600,2560,2400,2000,1800,1280,1200; 1/2 of each of these (which does not satisfy the synchronized reference point specifications.)
Maximum response frequency	400 divisions: 20 KHz (24.0 m/min on a scale where l = 20 μm) 300 divisions: 25 KHz (33.6 m/min on a scale where l = 20 μm) 200 divisions: 42 KHz (50 m/min on a scale where l = 20 μm) 120 divisions or less: 70 KHz (84 m/min on a scale where l = 20 μm)	1024 divisions: 6 KHz (7.2 m/min on a scale where l = 20 μm) 800 divisions: 8 KHz (9.6 m/min on a scale where l = 20 μm) 640 divisions: 10 KHz (12.0 m/min on a scale where l = 20 μm) 500 divisions: 15 KHz (18.0 m/min on a scale where l = 20 μm)	4000 divisions: 1 KHz (1.2 m/min on a scale where l = 20 μm) 3600 divisions: 1.1 KHz (1.3 m/min on a scale where l = 20 μm) 2400 divisions: 1.8 KHz (2.1 m/min on a scale where l = 20 μm) 1200 divisions: 4.7 KHz (5.6 m/min on a scale where l = 20 μm)
Minimum phase difference	100 ns		
Input level	Sin, Cos signal	0.6 Vp-p to 1.2 Vp-p with 120 Ω load	
	Compensation range	0.75 Vp-p to 1.2 Vp-p	
	Reference point signal	0.2 V to 1 Vp-p with 120 Ω load	
Alarms *1	Speed alarm (minimum phase difference time or maximum response frequency) Level alarm (0.6 Vp-p or less) Minimum alarm time: approximately 400 ms		Speed alarm (minimum phase difference time or maximum response frequency) Level alarm (0.7 Vp-p or less) Minimum alarm time: approximately 400 ms
Hysteresis	1 / 2048		
Linearity	± 1 / 1024 ²		
System startup time	Within 0.5 seconds after the power comes on line		
External dimensions	138 x 93 x 26 (mm) / 5.43" x 3.66" x 1.02" including protrusions		
Operating temperature	0 °C to 45 °C / 32 °F to 113 °F		
Storage temperature	-20 °C to 60 °C / -4 °F to 140 °F		
Mass	350g / 0.77 lbs		
Supplied accessories	Manual, output connector, connector cap, mounting screws		
Options	SET-P16-1 (for external reference point) Scale extension cable, external reference point extension cable Output connector with cable		

*1: The alarm function may not operate when the head output signal has an abnormal offset voltage generated due to a broken wire, etc.

*2: Only applies under ideal signal conditions.

*Contact us directly if you have special requirements for the specifications.