

High accuracy scale for feedback applications

- Compact high accuracy feedback scale.
- Keeps interpolation error to a minimum of 0.1 μm or less thanks to high accuracy internal circuitry.
- Resolution: 0.1 μm
- Measuring length: 70 to 1240 mm (2.7" to 48.8") (20 models)
- Alarm output in case of scale failure.
- A/B quadrature output and zero point signal by differential line driver.
- Perfect for positioning high accuracy NC machine tools or measuring equipment in a restricted installation space.

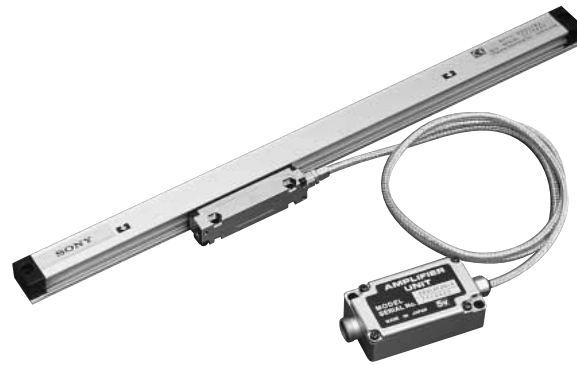

Specifications

Model	SH11-			
	C1A2	C1A3	C1B2	C1B3
Measuring length L mm (inch)	70/120/170/220/270/320/370/420/470/520/570/620 (2.7,4.7,6.6,8.6,10.6,12.6,14.5,16.5,18.5,20.4,22.4,24.4)	670/720/770/820/920/1020/1140/1240 (26.3,28.3,30.3,32.3,36.2,40.1,44.8,48.8)	70/120/170/220/270/320/370/420/470/520/570/620 (2.7,4.7,6.6,8.6,10.6,12.6,14.5,16.5,18.5,20.4,22.4,24.4)	670/720/770/820/920/1020/1140/1240 (26.3,28.3,30.3,32.3,36.2,40.1,44.8,48.8)
Resolution	0.1 μm			
Minimum phase difference	0.16 μs		0.3 μs	
Engraving pitch	16 μm			
Accuracy (at 20 °C / 60 °F)	± 2 μm	± 3 μm	± 2 μm	± 3 μm
Max. response speed	24 m/min		12 m/min	
Zero point	2 points within the measuring length. (measuring length 70 mm/2.7": 1 point in the center)			
Light source	Infrared LED			
Photo detector	Photo diode			
Expansion coefficient	(8.8 ± 1) × 10 ⁻⁶ / °C			
Operating temperature	0 °C to 45 °C / 32 °F to 113 °F			
Storage temperature	-10 °C to 60 °C / 14 °F to 140 °F			
Humidity range	Relative humidity 30 to 90 % (no condensation)			
Protective design grade	(1) Equivalent to IP53* (2) Improvement of the protective design grade (see the instruction manual)			
Atmosphere	Corrosive gas should not be contained in the atmosphere.			
Vibration resistance	68.6 m/s ² (according to our vibration test data, 30 to 1000 Hz for 30 min)			
Shock resistance	147 m/s ² (according to our vibration test data, 11ms, 3 times in each of the X, Y, Z directions)			
Zero point detection speed	Depends on the model (0.01 to 0.2 m/min)			
Power supply	5V DC ± 5%			
Power consumption	Approx. 250 mA			

*Air purge may be used to increase resistance to dust, humidity and condensation.

Dimensions

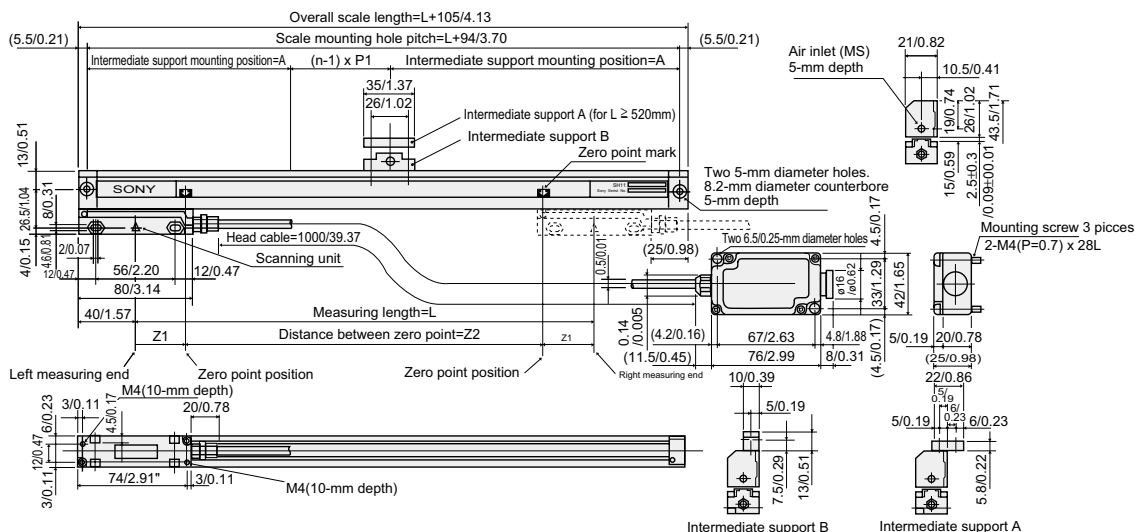

SH11-	007	012	017	022	027	032	037	042	047	052	057	062	067	072	077	082	092	102	114	124	
Measuring length L (mm)	70	120	170	220	270	320	370	420	470	520	570	620	670	720	770	820	920	1020	1140	1240	
Intermediate support n										1	1	1	1	1	1	1	1	2	2	2	
Intermediate support A (mm)										307	332	357	382	407	432	457	507	380	420	450	
Scale mounting hole pitch P1 (mm)																		354	394	434	
Zero point position	Z1 (mm)	35	35	35	35	35	35	35	35	35	35	35	35	35	35	35	35	35	35	45	45
	Z2 (mm)		50	100	150	200	250	300	350	400	450	500	550	600	650	700	750	850	950	1050	1150

Unit : mm/inch