

# PL

# PL81/PL82

Magnescale® Digiruler®

Integrated reader head and Interpolator unit for position control

- Compact design
- Interpolator unit for automated position control
- High response speed: 300 m/mim
- Resolution: 10 μm, 20 μm, 25 μm, 50 μm, 100 μm



Example for connection

Scale	Headcable
SL110/130	PL81/82

## Dimensions

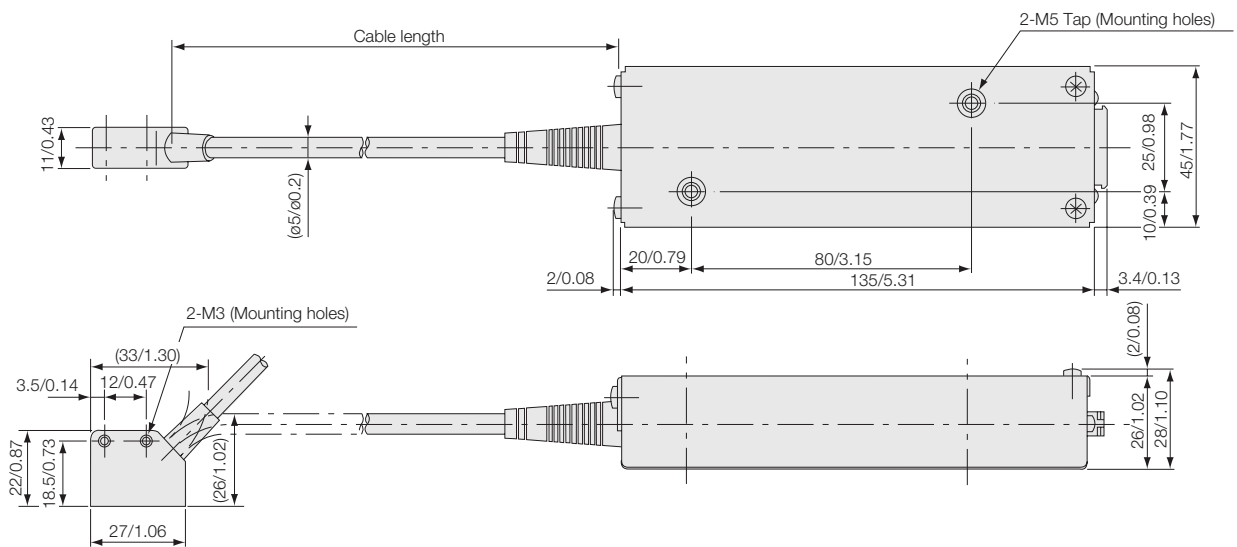

Unit : mm/inch

## Specifications

Model	PL81					PL82				
	-3	-5	-7	-A	-B	-3	-5	-7	-A	-B
Cable length (inch)	3m (118.1)	5m (196.9)	7m (275.6)	10m (393.7)	15m (590.6)	3m (118.1)	5m (196.9)	7m (275.6)	10m (393.7)	15m (590.6)
Mass (g)	640	720	800	910	1050	640	720	800	910	1050
Accuracy (20 °C / 68 °F)	(50 + 10L / 1000) μm (L: measuring length in mm) (Varies with scale SL 110/130)									
Resolution	10, 20, 25, 50, 100 μm									
Alarm display	LED turns orange. (green for normal operation)									
Output circuit	Open Collector Max.rated voltage:40 V Max.rated current:100 mA					AB phase signal by line driver (compliance EIA-422)				
Max. response speed	300 m/ min									
Clearance (inch)	Max. 1.5 mm (0.059)									
Power supply	DC 10 ~ 30 V					DC 5 V ± 5 %				
Power consumption	Max. 70 mA (2.1 W)					Max. 300 mA (1.5 W)				
Protective design grade	Equivalent to IP67 (exclude head cable)									
Operating temperature	0 °C to 45 °C / 32 °F to 113 °F									
Storage temperature	-20 °C to 50 °C / -4 °F to 122 °F									